

# Temperature measurement *TMD 832 head transmitter*

**SMART head transmitter  
with HART protocol for RTD,  
Thermocouple and mV input signals**



## Applications

- Programmable transmitter for transforming an input signal into the scalable 4...20 mA output signal.
- Linearisation of input signals .
- Setting up using HART protocol.

## Features and benefits

- No separate power supply.
  - SMART technology with HART communication protocol
  - Digital technology
  - Galvanic isolation
- Input for:
- RTD (3 versions)
  - Thermocouple (12 types)
  - Resistance (Ohm)
  - Voltage (mV)

Endress + Hauser

Nothing beats know-how



# Function

The SMART technology based digital transmitter TMD 832 can be set up for varying measurement tasks by configuration of e.g. sensor type, measurement range, input behaviour, input filter and threshold value, sensor breakage monitoring and further parameters. Configuration is done via a hand held operating unit or a PC with the respective interface and configuration

software, e.g. Commuwin II. The digital communication is superimposed on the 4...20 mA output signal and offers the possibility to transmit condition information during operation without disturbing the actual measurement value. The input is galvanically isolated from the output; another guarantee for high operational reliability.

# Input

Using software a large number of different input types can be set up in the same transmitter:

- Resistive thermometers (RTD): Pt100, Pt1000 to IEC 751 and Ni100 to DIN 43760
- Resistance: Two ranges can be selected 0...400 Ohm and 0...4000 Ohm
- Thermocouples: B, E, J, K, N, R, S, T to IEC 584, L and U to DIN 43760 C and D to ASTM E988
- Voltage: Range 10.0 to 80.0 mV.

Pt100-, Pt1000-, Ni100- and Ohm- inputs

are constructed for 2, 3 or 4 wire single sensor inputs.

The 2 wire connection for resistive thermometers (RTDs) can be compensated using software. Using the microprocessor it is possible to change the input signal by  $\pm 10$  K e.g. to compensate sensor aging. If the transmitter is installed this offset can be set up using a PC in the control room, e.g. using Commuwin II or by using the hand held unit on site. Zero and measurement span are set up using software; these values are not required when the order is placed.

# Output

The TMD 832 transmits a 4...20 mA output signal that can be either a direct or reverse signal output. The output signal can be selected to be either a 4...20 mA or 20...4 mA signal. Due to SMART technology the digital (HART) communication is superimposed on the 4...20 mA signal. The 4...20 mA signal is linear to temper-

ature, voltage or resistance measurements. The built-in error monitor recognises a defective sensor as well as a transmitter failure. In this case the current value is below 3.8 mA or above 21 mA. Using the software the current value for defective sensor detection can be set to 3.8 mA or 21 mA.

# Electrical connection

## Terminal connections:

- 2 For compensation cable on RTDs
- 3 Input (- on thermocouple)
- 4 Input (+ on thermocouple)
- 5 For compensation cable on RTDs
- + Power supply +
- Power supply -

## Sensor connections:

- Example ①: Thermocouple
- Example ②: Resistive transmitter 2-wire
- Example ③: Resistive transmitter 3-wire
- Example ④: Resistive transmitter 4-wire

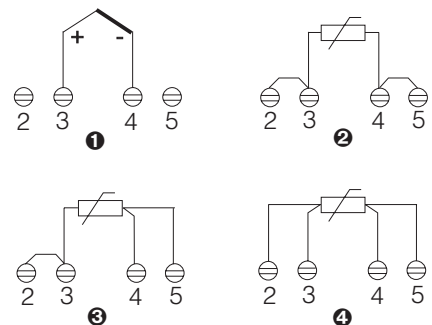
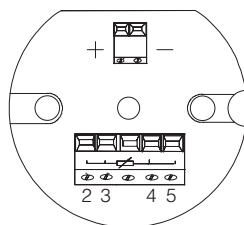

## power supply and communication connections:

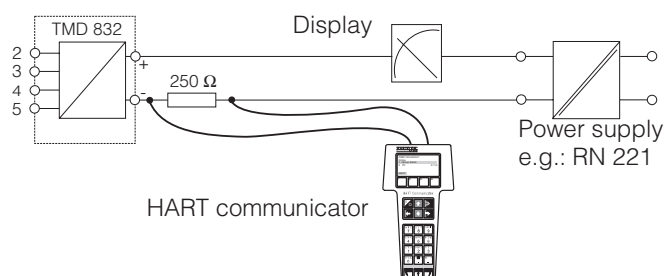

## Configuration

### HART menu

The TMD 832 is set up via a menu that contains the unit features in matrix form. Using HART a user friendly setting up and data read out is guaranteed. The TMD 832 memory retains all setting up information even in the case of a power failure.

### Standard configuration

Unless requested the TMD 832 is delivered with the following standard settings:  
Pt100 Sensor, -200...+850 °C, 3-wire  
4...20 mA output,  
low current on sensor failure, all values set to "0".

## System integration

### System integration

The TMD 832 SMART transmitter, with HART protocol can be simply integrated into process control systems (PLC, PCS, etc.)

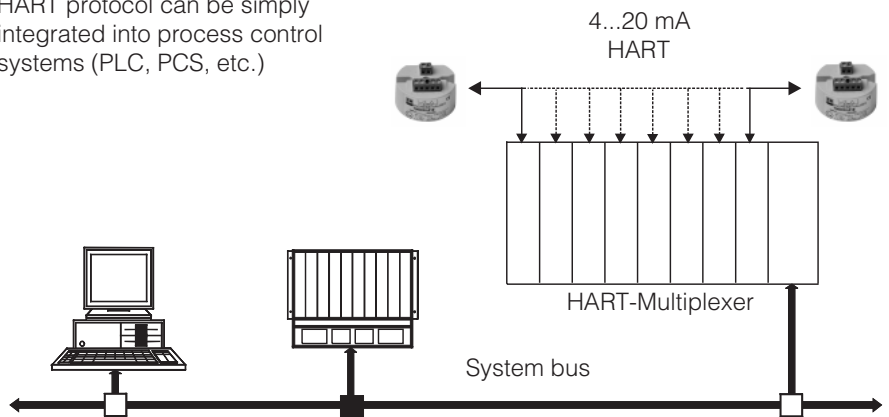

## Configuration using hand-held module

### Handheld

The TMD 832 is fitted with a HART protocol and can be set up using the DXR 275 HART universal communicator.

The DXR 275 can be directly connected to the TMD 832 or by means of the 4...20 mA connection e.g. in the control room.

Data transfer is displayed in English or German on the LC-display of the DXR 275.

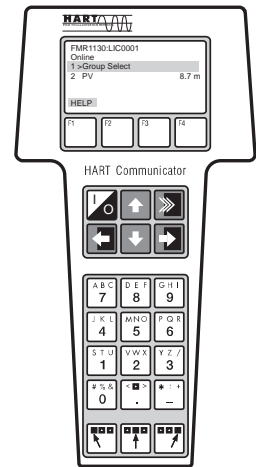

## Configuration using a personal computer.

### Personal Computer

The TMD 832 can be set up using a PC and the Commuwin II operating program.

Connection to the PC is via the Commubox FXA 191.

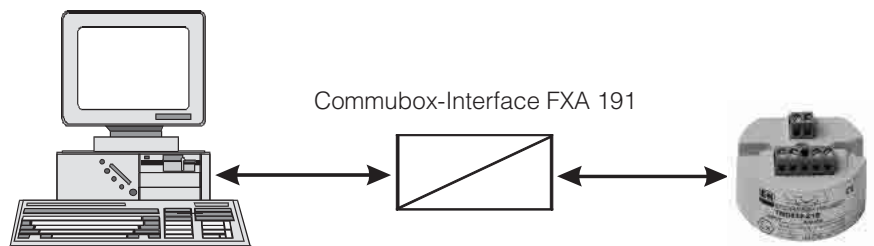

## Technical data

### General information

Manufacturer	Endress+Hauser
Description	TMD 832 temperature head transmitter
Unit function	Digital 2 wire head transmitter with galvanic isolation

### Application areas

Transmitter	Transforming resistance or voltage signals into 4...20 mA current signals, scalable measured signal and output signal.
-------------	--

### Operation and system construction

Measuring principal	Measured value recording using analogue/digital conversion, the recorded values are then analysed and retransmitted as a 4...20 mA measured signal loop via a digital/analogue convertor. Additionally digital information (HART protocol) is superimposed on this 4... 20 mA signal. This is used for communication with a relevant communications unit or system.
Measurement system	Microcontroller controlled analogue/digital and digital/analogue conversion integrated fault monitor.

### Input

RTD input	
Types	Pt100 and Pt1000, to IEC75; Ni100 to DIN 43760
Measurement range	Pt100, Pt1000: -200...+850 °C; Ni100: -60...+180 °C
Min. span <sup>(1)</sup>	10 °C
Connection	2-, 3-, 4- wire
Sensor current	<0.2 mA

Resistance input	
Measurement range	0...400 Ω and 0...4000 Ω
Min. span <sup>(1)</sup>	Range 400 Ω: 5 Ω / Range 4000 Ω: 50 Ω
Connection	2-, 3-, 4- wire
Sensor current	<0.2 mA

Thermocouple input (TC)			
Measurement type	B,E,J,K,N,R,S,T (IEC 584); L,U (DIN 43710); C,D (ASTM E988)		
Measurement range/ Min. span	Type	Measurement range	Min. span*
	B	*400...+1820 °C	100 °C
	C	*400...+2300 °C	100 °C
	D	*400...+2300 °C	100 °C
	E	-200...+1000 °C	20 °C
	J	-200...+1000 °C	20 °C
	K	-200...+1370 °C	20 °C
	L	-200...+900 °C	20 °C
	N	-180...+1300 °C	20 °C
	R	0...+1760 °C	25 °C
	S	0...+1760 °C	25 °C
	T	-200...+400 °C	20 °C
	U	-200...+600 °C	40 °C
	* non linearised range from 0...400 °C is admissible.		
Input impedance	>10 MΩ		

**Input  
(continued)**

Input resolution	Type	Input resolution
	B	1.0 °C
	C	0.25 °C
	D	0.25 °C
	E	0.1 °C
	J	0.1 °C for T > -160 °C; 0.2 °C for T < -160 °C;
	K	0.1 °C for T > -160 °C; 0.3 °C for T < -160 °C;
	L	0.1 °C
	N	0.1 °C for T > -80 °C; 0.2 °C for T < -80 °C;
	R	0.1 °C for T > 1000 °C; 0.1 °C for T < 1000 °C; 0.4 °C for T < 150 °C
	S	0.1 °C for T > 150 °C; 0.4 °C for T < 150 °C
	T	0.1 °C for T > -120 °C; 0.2 °C for T < -120 °C
U	0.1 °C	
Cold junction Compensation	Selectable internal or fixed by software.	

Voltage input (mV)	
Measurement range	-10.0...+80 mV
Min. span <sup>(1)</sup>	3 mV
Input impedance	> 10 MΩ
Input resolution	3 μV

Note	<p><sup>(1)</sup> Spans can be sent to each value below the minimum because the D/A convertor accuracy is dependent on the resolution; the analogue resolution can be calculated as follows:</p> $\text{Resolution [\%]} = \frac{100 \times \text{input resolution}}{\text{Span set}} + 0.025$
------	--

**Output**

Output signal	4...20 mA or 20...4 mA
Failure signal	3.8 mA or 21.0 mA presettable
Load	(Power supply - 12,5 V) / 0,022 A
D/A resolution	4 μA
D/A convertor-accuracy	±0.025% of the calibrated span
Analogue accuracy	Analogue accuracy, referenced to the output, can be calculated as follows: D/A convertor accuracy + digital accuracy. Example: Pt100 input, 0...100 °C calibrated span ±0.025% of calibrated span + ±0.12 K digital accuracy = ±0.145 K total accuracy.
Long-term stability (12 months)	±0.1% of the span or ±0.1 °C

**Measurement accuracy**

RTD input	
Digital accuracy <sup>(2)</sup>	±0.12 °C, contains calibration and linearisation errors
Input resolution	0.1 °C
Linearity	0.12 °C

**Measurement accuracy  
(continued)**

Linearisation	Using software module
Influence on connection cable	2-wire: Compensation per software 3-wire: No influence, when $R < 100 \Omega$ 4-wire: No influence

Resistance input	
Digital accuracy <sup>(2)</sup>	Range 400 $\Omega$ : $\pm 0,04 \Omega$ / Range 4000 $\Omega$ : $\pm 0,5 \Omega$ contains calibration error
Input resolution	Range 400 $\Omega$ : $\pm 0,03 \Omega$ / Range 4000 $\Omega$ : $\pm 0,3 \Omega$
Linearity	Range 400 $\Omega$ : $\pm 0,04 \Omega$ / Range 4000 $\Omega$ : $\pm 0,5 \Omega$
Influence of connection cable	2-wire: Compensation per software 3-wire: No influence, when $R < 100 \Omega$ 4-wire: No influence

Thermocouple input (TC)		
Digital accuracy <sup>(2)</sup>	Type	Digital accuracy
	B	1.0 °C
	C	0.5 °C
	D	0.5 °C
	E	0.15 °C
	J	0.15 °C for $T > -160 \text{ °C}$ ; 0.25 °C for $T < -160 \text{ °C}$
	K	0.15 °C for $T > -160 \text{ °C}$ ; 0.4 °C for $T < -160 \text{ °C}$
	L	0.15 °C
	N	0.15 °C for $T > -80 \text{ °C}$ ; 0.3 °C for $T < -80 \text{ °C}$
	R	0.15 °C for $T > 1000 \text{ °C}$ ; 0.25 °C for $T < 1000 \text{ °C}$ ; 0.6 °C for $T < 150 \text{ °C}$
	S	0.15 °C for $T > 150 \text{ °C}$ ; 0.6 °C for $T < 150 \text{ °C}$
	T	0.15 °C for $T > -120 \text{ °C}$ ; 0.6 °C for $T < -120 \text{ °C}$
	U	0.15 °C
The digital accuracy contains calibration and linearisation errors. Cold junction error: 0.5 °C at 25 °C		

Voltage input (mV)	
Digital accuracy <sup>(2)</sup>	10 $\mu\text{V}$ contains calibration error
Input resolution	3 $\mu\text{V}$
Linearity	10 $\mu\text{V}$

Temperature drift	30 ppm/°C for digital readout 50 ppm/°C for analogue output
Warm up time	60 s
Reaction time	400 ms
Note	<sup>(2)</sup> Direct read out of the output data with digital accuracy can be done using hand operation modules or via the field bus.

**Application condition**

Installation conditions	
Installation angle	no limitation

**Application conditions  
(continued)**

Ambient conditions	
Ambient temperature	-40 °C ... +85 °C
Storage temperature	-45 °C ... +90 °C
Humidity	0...95%, without condensation

**Electromagnetic compatibility**

Interference immunity	according to EN 50082-2
Interference emission	according to EN 50081-1

**Display and operating level**

Display	None
Operating surface	HART and operating module DXR 275 or software package Commuwin II, operational under Windows 3.11/95/NT, for setting up, transmission and visualisation of measured data

**Power supply**

Power supply	12.5...36 V <sub>DC</sub> ; 13.0...30 V <sub>DC</sub> for Ex-Version
Voltage drop	12.5 V; 13 V for Ex-Version
Allowable ripple	5% of the power supply within the voltage range.
Galvanic isolation	Isolation between input and output 500 V AC for 1 minute

**Serial connection**

Protocol	HART®
Transmission speed	1200 baud
Number on addresses	32
Max. cable length	3000 m

**Certification**

CE -Mark	The units comply with the legal requirements of the EU directives.
----------	--

Certificate	CESI Ex-98.D.090, EEx ia IIC C <sub>i</sub> ≅ 0      C <sub>o</sub> ≤ 3 μF L <sub>i</sub> ≅ 0.26 mH      L <sub>o</sub> ≤ 3 mH
Max. input voltage	U <sub>i</sub> = 30 V
Max. input current	I <sub>i</sub> = 100 mA
Max. input power	P <sub>I</sub> = 0.75 W
Max. ambient temperature	T4 = +85 °C T5 = +70 °C T6 = +60 °C

## Further documentation

**System information**  
*Commuwin II*  
Order No.: SI 018F/00/en

**Operating manual**  
*Commuwin II*  
Order No.: BA 124F/00/en

**Technical information**  
*Commubox FXA 191*  
Order No.: TI 237F/00/en

**Operating manual**  
*TMD 832 head transmitter*  
Order No.: KA 076R/09/a3

## How to order

TMD 832 temperature head transmitter			
<b>Version</b> R - Version for non-Ex areas Z - Ex certificate: EEx ia IIC T4, T5, T6			
<b>Input/measurement range</b> 1 - Standard factory settings 2 - Customer specific calibration			
<b>Communication</b> E - HART protocol			
TMD832-			Order code

### United Kingdom

Endress+Hauser Ltd.  
Floats Road  
Manchester  
M23 9NF  
Tel. (0161) 286 - 5000  
Fax. (0161) 998 - 1841  
<http://www.endress.com>

### Export division

Endress+Hauser  
GmbH+Co.  
Instruments International  
P.O. Box 2222  
D-79574 Weil am Rhein  
Germany  
Tel. (07621) 975-02  
Fax (07621) 975-345  
<http://www.endress.com>

Environmentally friendly  
Bleached without chlorine



**Endress + Hauser**  
Nothing beats know-how

